

CAD FILE:

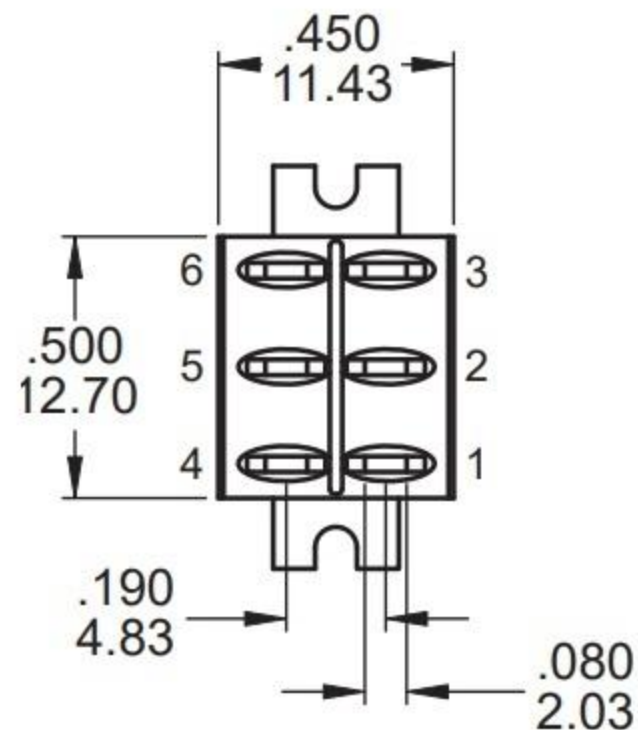
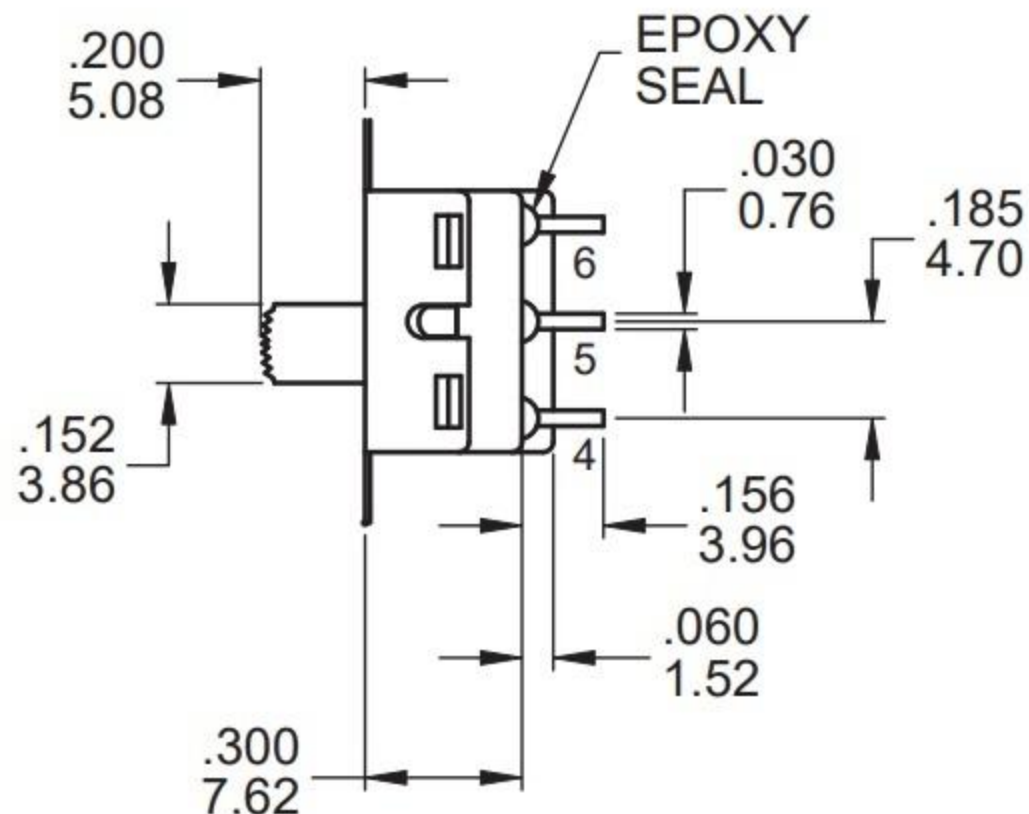
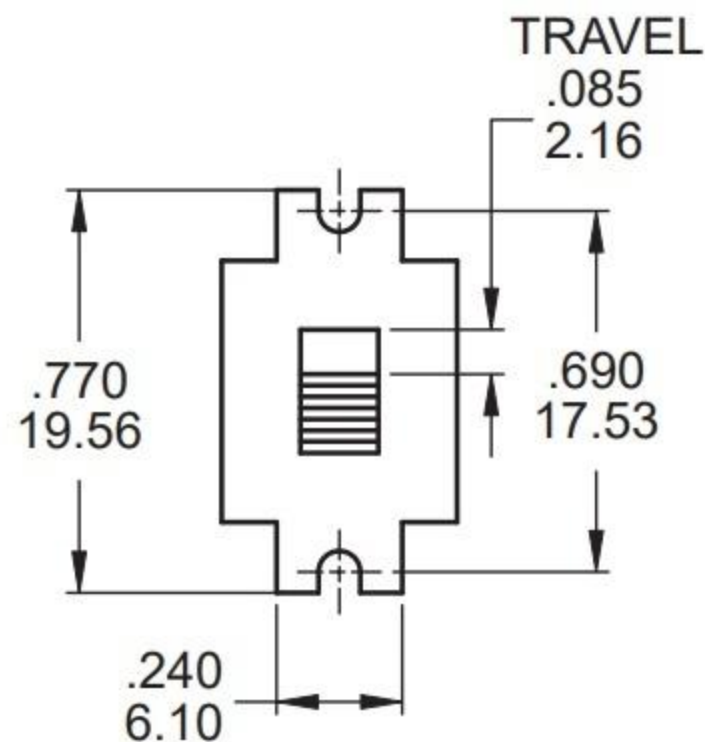

拨动开关立式技术参数:

1. 额定负荷: AC 125V 2A 3A
2. 接触阻抗: $\leq 50m\Omega$
3. 绝缘阻抗: $\geq 100m\Omega$ DC500V
4. 耐焊温度: $250 \pm 5^\circ 5s$
5. 使用寿命: 10,000 cycles
6. 使用温度: $-25^\circ C$ to $80^\circ C$
7. 使用湿度: $\leq 85\% RH$
8. 操作力: 160gf 256gf 300gf 可定制
9. 手柄长度: 2mm-10mm 可定制

注: "*"表示关键尺寸(4个)

NO.	PARTS	MATERIALS	Q'TY	FINISH	TOLERANCE UNLESS SPECIFIED			
8					WITHIN OVER			
7	STEEL BALL	STEEL	1	NATURAL	A		2012-10-28	初版
6	SPRING	STEEL WIRE	1	NATURAL	ISSUE		DATE	DESCRIPTIONS OF REVISION
5	CONTACT CLIP	PBS STRIP	2	Ag PLATED	TITLE : VERTICAL SLIDE SWITCH		UNIT : mm	APPD.
4	TERMINAL	BRASS STRIP	8	Ag PLATED	MODEL:		SCALE: 3:1	DRWG NO.:
3	BASE	PHENOLIC RESIN	1	NATURAL	东莞市高迪电子有限公司		DWN.	2012-10-26
2	FRAME	STEEL STRIP	1	Ni PLATED			CHK'D	
1	KNOB	POM	1	BLACK			APPD.	2012-10-26